

TITLE: Filter Board	
Engineer: Samuel Burnett	
Document Number:	REV: 1
Date: 1/10/2020 11:45 AM	Sheet: 1/5

# Mux/Demux

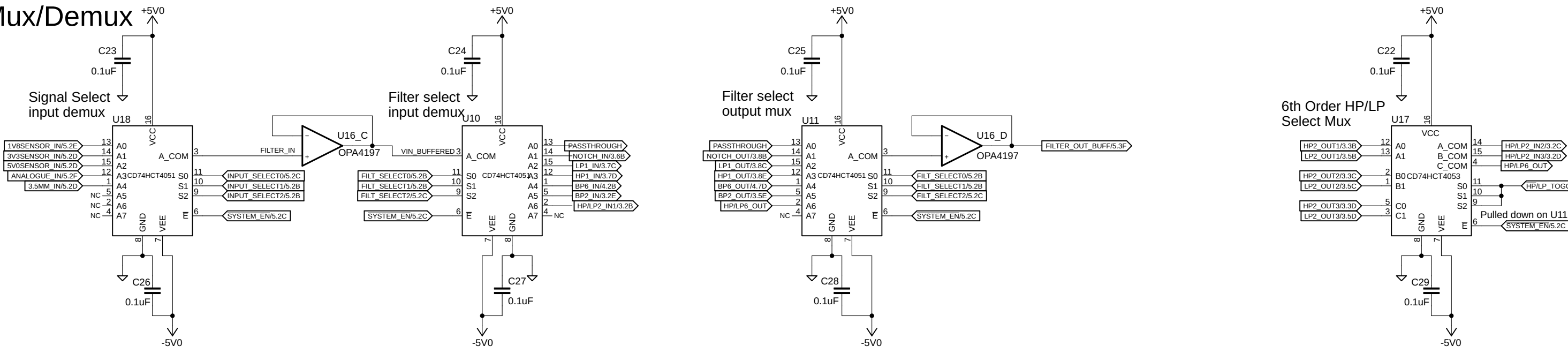

# Digital Pots

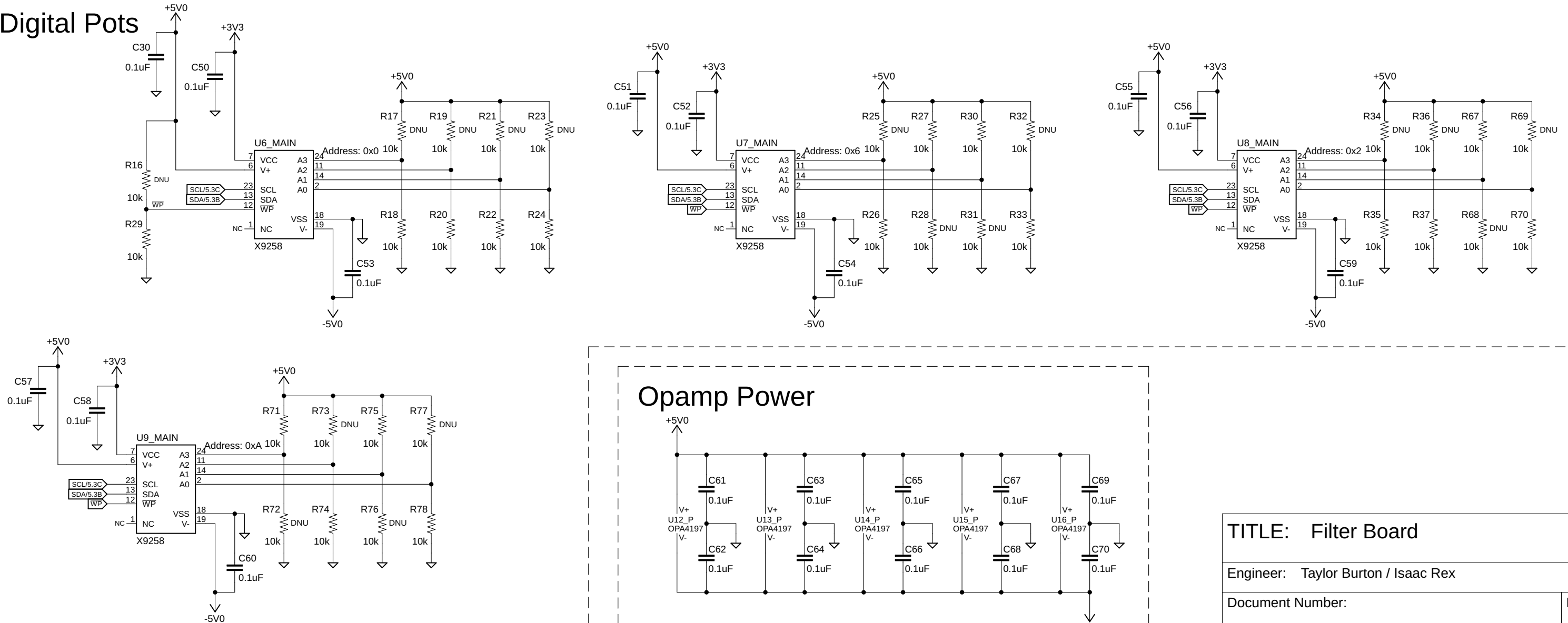

TITLE: Filter Board	
Engineer: Taylor Burton / Isaac Rex	
Document Number:	REV: 1
Date: 1/10/2020 11:45 AM	Sheet: 2/5

### 2nd Order Highpass/Lowpass

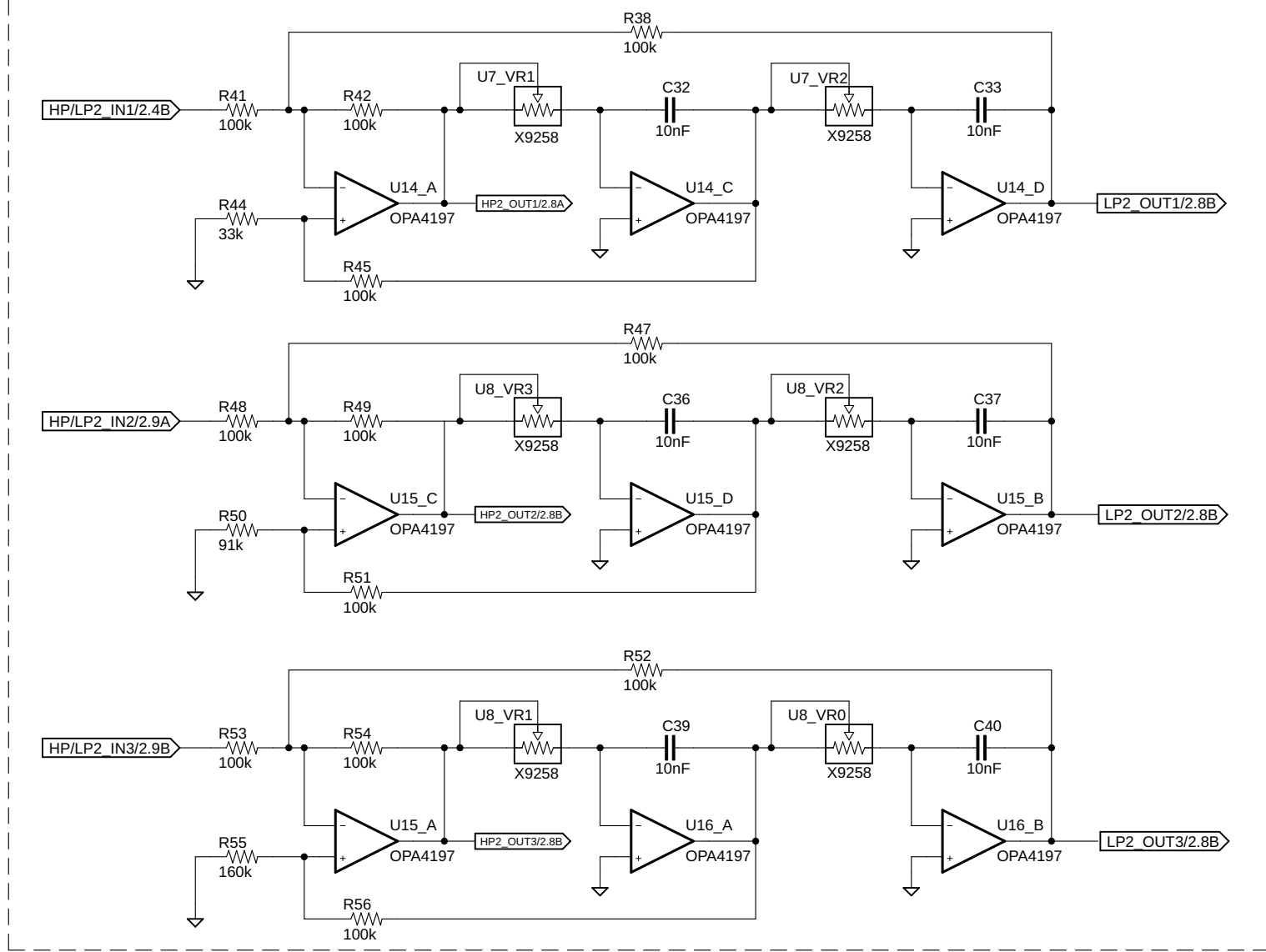

### Notch Filter

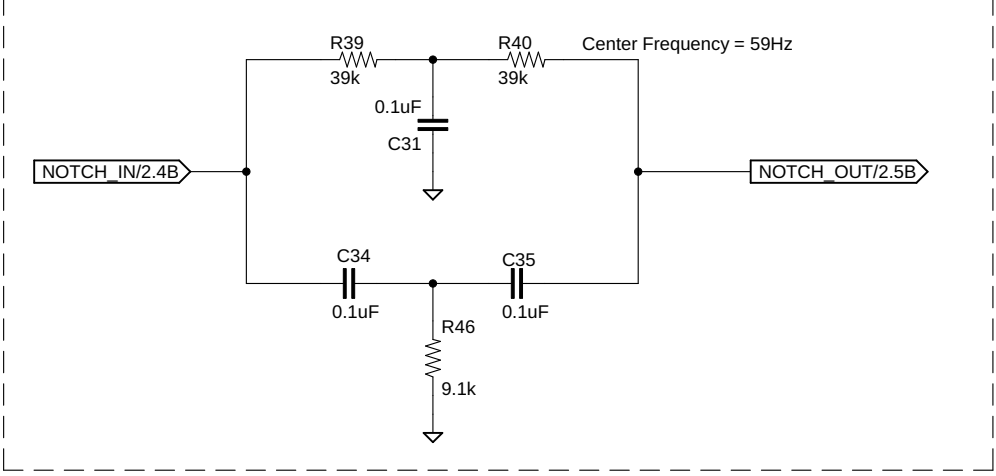

### 1st Order Low Pass

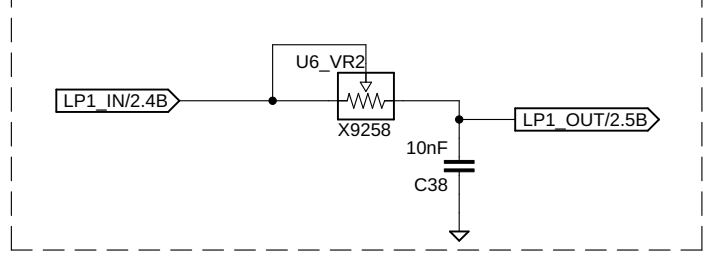

### 1st Order High Pass

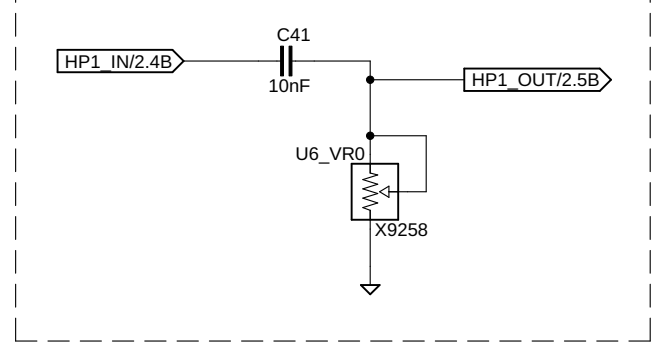

### 2nd Order Bandpass

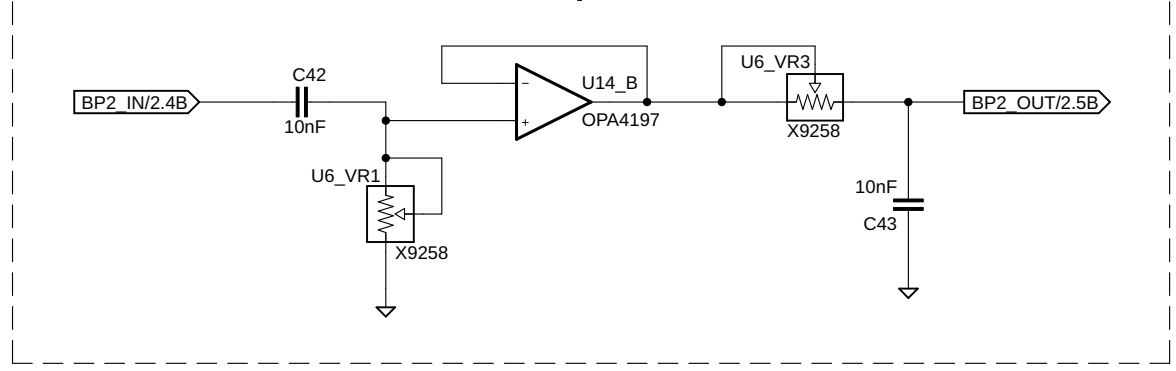

TITLE: Filter Board	
Engineer: Taylor Burton / Isaac Rex	
Document Number:	REV: 1
Date: 1/10/2020 11:45 AM	Sheet: 3/5

# 6th Order Bandpass

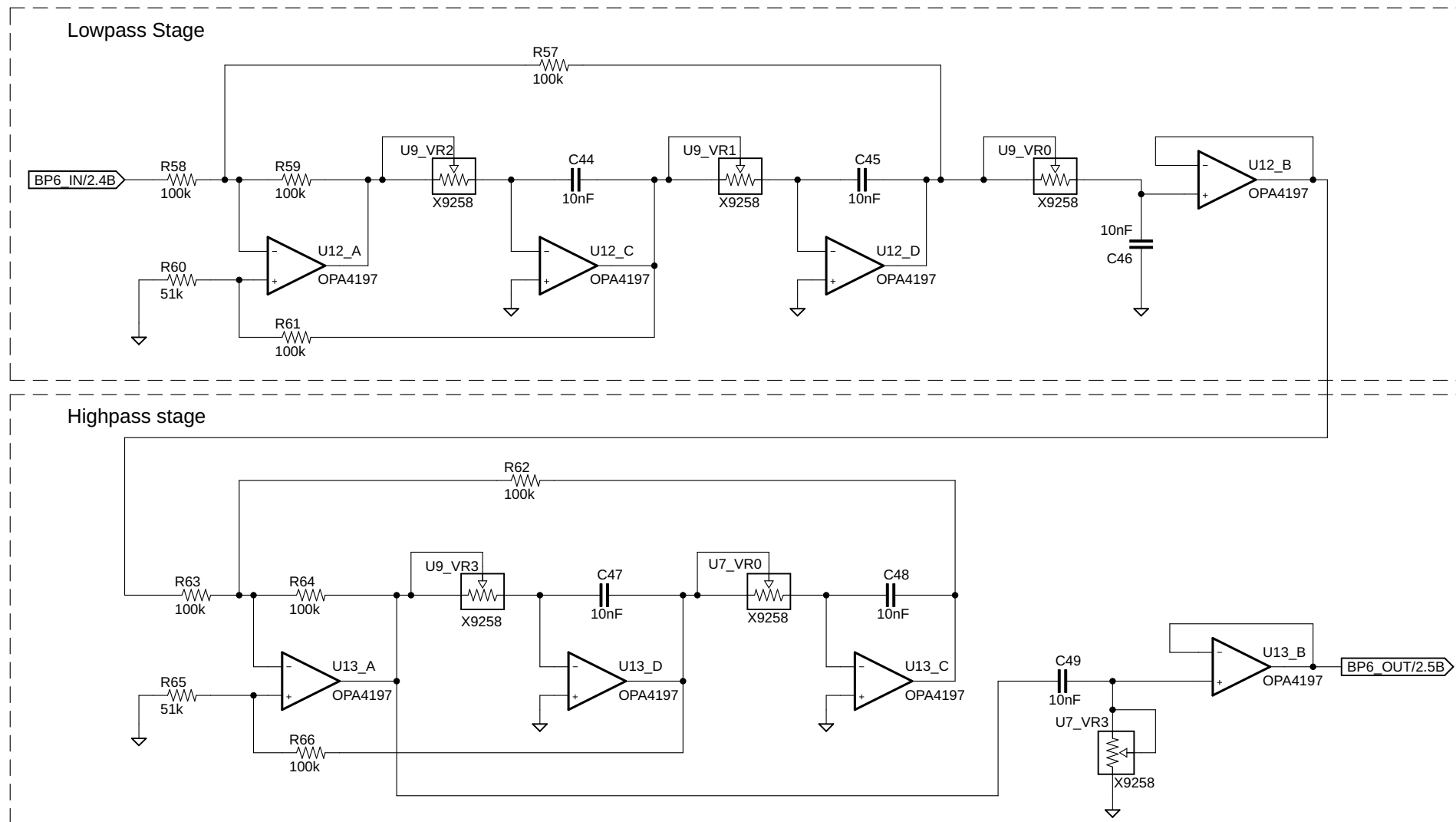

TITLE: Filter Board	
Engineer: Taylor Burton / Isaac Rex	
Document Number:	REV: 1
Date: 1/10/2020 11:45 AM	Sheet: 4/5

## Power Connectors

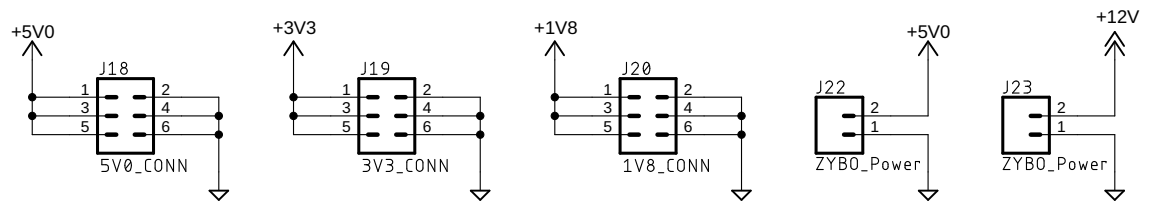

## Board Control Signals

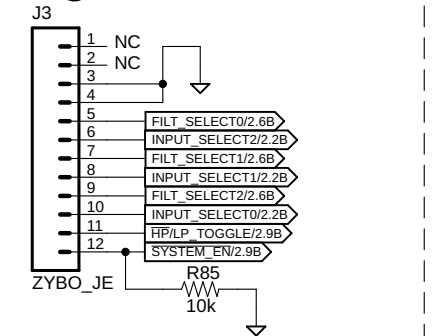

## Communication Breakout

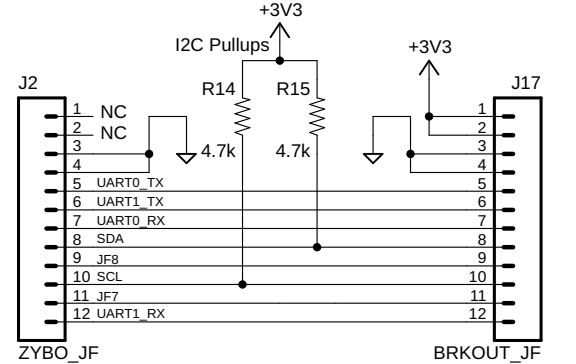

## PMOD Breakouts

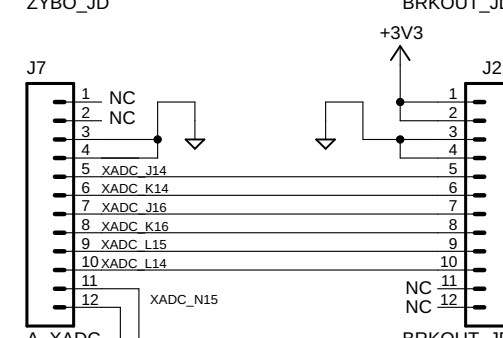
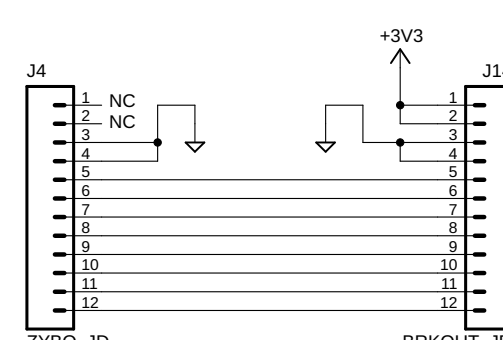
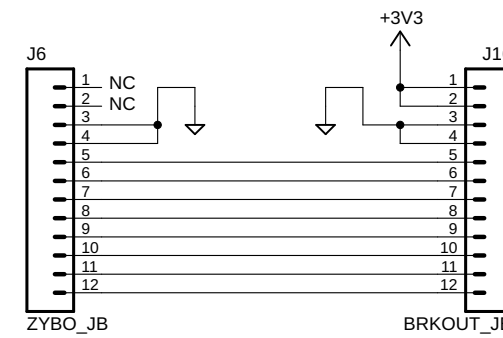
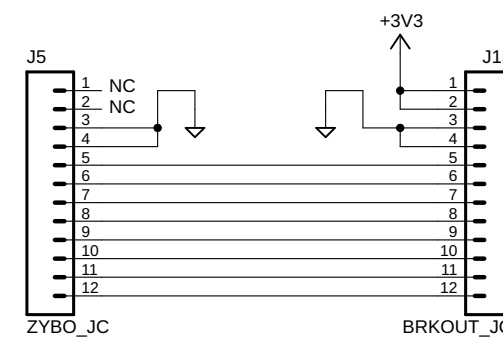

## Filter Inputs/Output

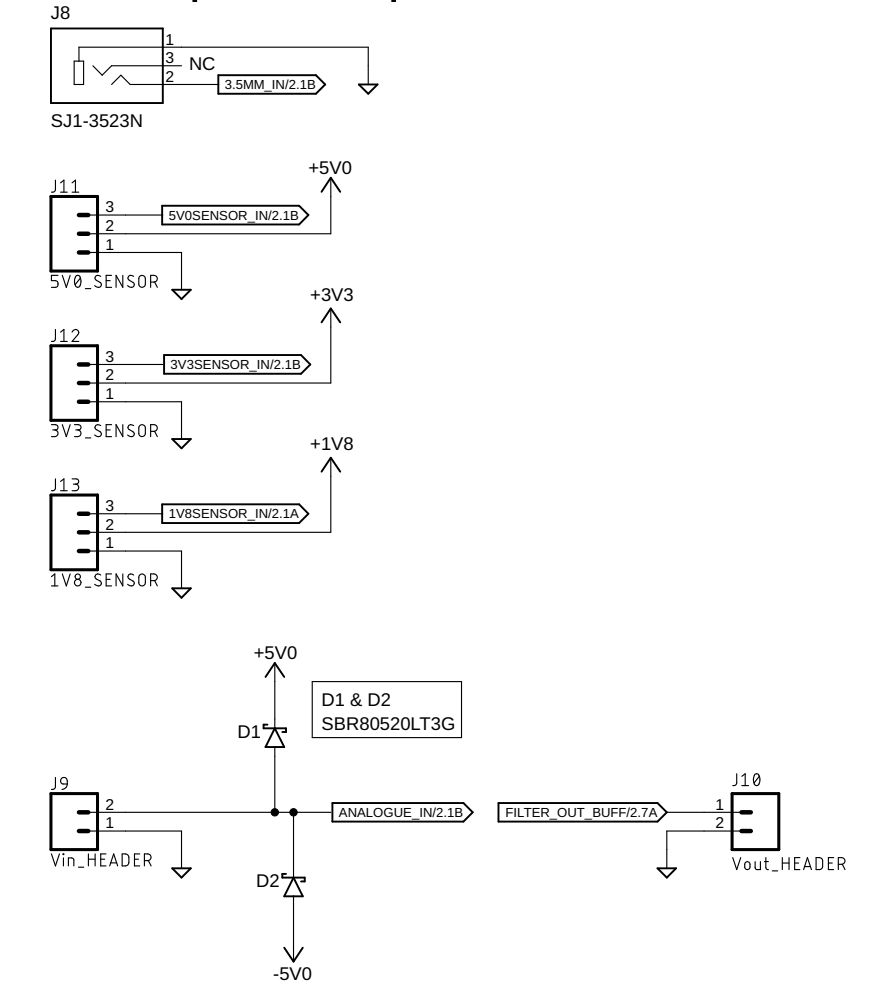

## Level Shifter Power

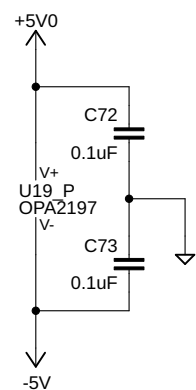

## Level shifter

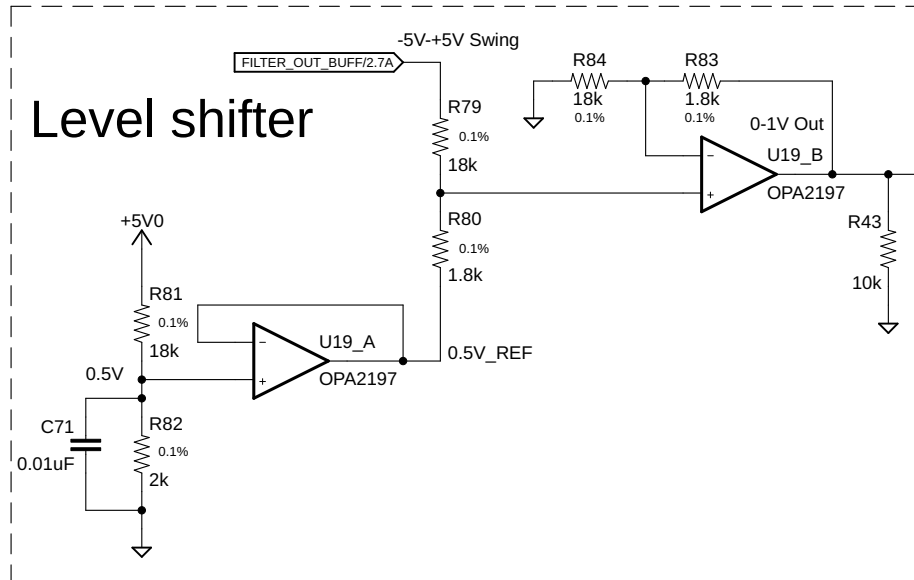

TITLE: Filter Board

Engineer: Isaac Rex

Document Number:

REV:  
1

Date: 1/10/2020 11:45 AM

Sheet: 5/5